



## General Information

### Air Release Valves & Air Release Valve Sets

#### Product Categories

1.1 Model 986-04 Data Sheet	2-3
1.2 Model 986-01 Data Sheet	4
1.3 Model 986-03 Data Sheet	5
1.4 Model 985-01 Lifting Device Data Sheet	6
1.5 Model 985-00 Tapping Device Data Sheet	7
1.6 Model 986-04 Maintenance Information	8-9
1.7 Model 986-01 Parts List	10
1.6 Model 986-03 Parts List	11

# Automatic Air and Vacuum Valve for Waste Water



## Model 986-04

ARV set for underground installation,  
for operating range: 0 – 250 PSI (17.2 Bar)

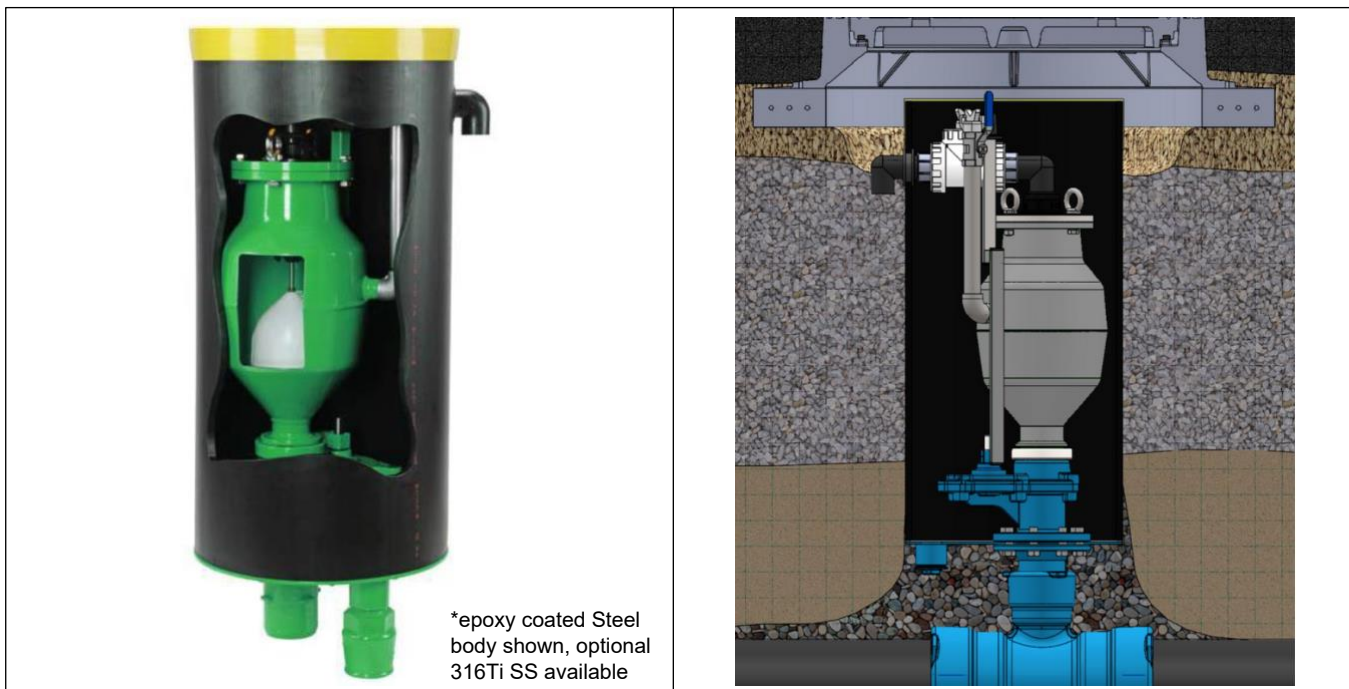

\*epoxy coated Steel body shown, optional 316Ti SS available

### Features:

The Model 986 automatic air and vacuum valve set consists of a polyethylene (PE) shaft with shut-off and an ARV, replacing other complex and expensive manhole constructions. Eliminate confined space entry, acc. to OSHA regulations. The set can be installed on sewage pipes by use of a double strap saddle. All maintenance and repair work for this air valve set can be done from the surface, avoiding all the dangers related to manhole access.

Medium: Wastewater  
 Maximum Operating Pressure: 250 PSI (17.2 Bar)  
 Operating Range: 0 - 250 PSI (17.2 Bar)  
 Connection to Pipe: 3" ANSI Flange

### Valve Maintenance:

Close shut-off valve. The valve is provided with two flushing connections reaching up to the cover. By connecting flushing lines minor dirt in the valve can be flushed out quickly and easily. Only in case of major dirt bodies the valve must be opened and cleaned manually.

Type	Size ANSI	Maximum Pressure PSI/Bar	Pipe Cover Depth ft./m	Overall Height Inch/mm	Overall Width Inch/mm	Weight lbs./Kg
Flange	3" ANSI	0-250 PSI 17.2 Bar	3.3 ft. 1.0 m	25.6" 780 mm	17.9" 455 mm	128 lbs. 58 Kg
Flange	3" ANSI	0-250 PSI 17.2 Bar	4.1 ft. 1.25 m	38.4" 975 mm	17.9" 455 mm	137 lbs. 62 Kg
Flange	3" ANSI	0-250 PSI 17.2 Bar	4.9 ft. 1.5 m	48.2" 1,225 mm	17.9" 455 mm	176 lbs. 89 Kg

# Automatic Air and Vacuum Valve for Waste Water



Air Release Flowrate

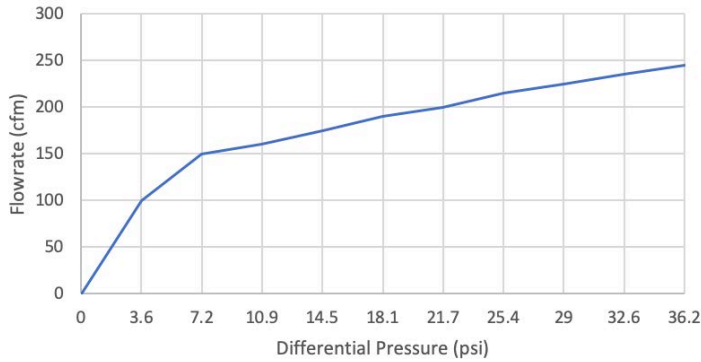

Operation Flowrate

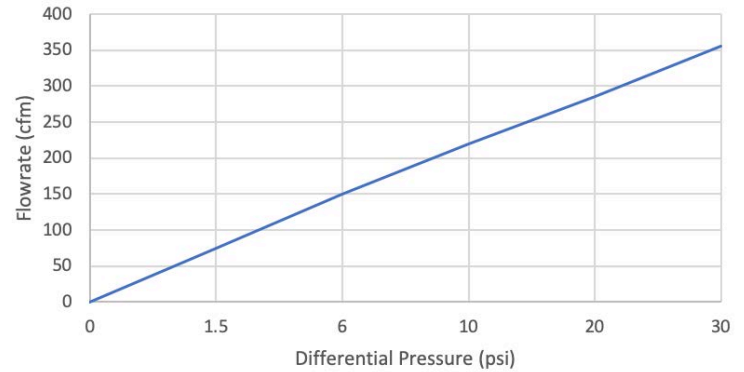

Vacuum Flowrate

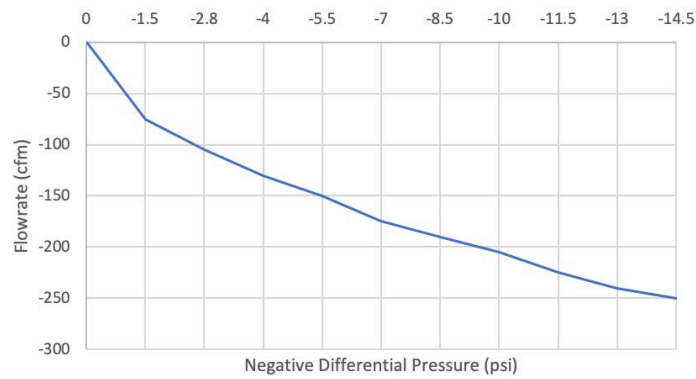

**Material:**

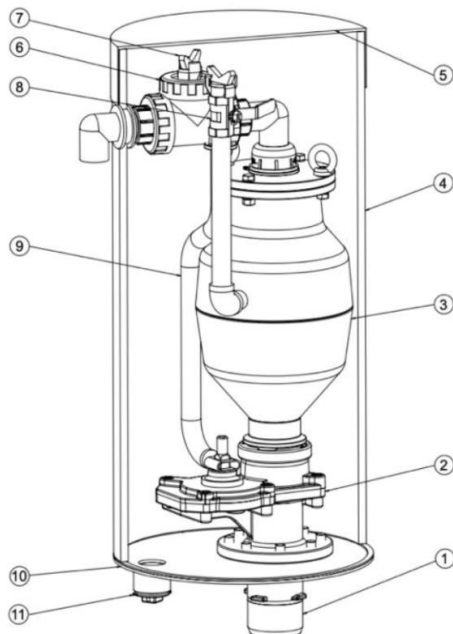

#	Component	Material
1	Spigot end 3" or Flange with threaded bolts	GGG 40, H-TEC epoxy powder coated
2	Shut-off device	GGG 40, H-TEC epoxy powder coated
3	Air valve (986-01)	316Ti Stainless Steel
4	Shaft cylinder	HDPE
5	Cover	HDPE
6	Three-way ball valve	PVC
7	Hose coupling	PE
8	Ball valve	Stainless Steel
9	Operating rod	Stainless Steel
10	Base plate	Steel - H-TEC epoxy powder coated
11	ZAK*-Plug	GGG 40, H-TEC epoxy powder coated

# Air Release Valve for sewage water 250 PSI

# 986-04SS

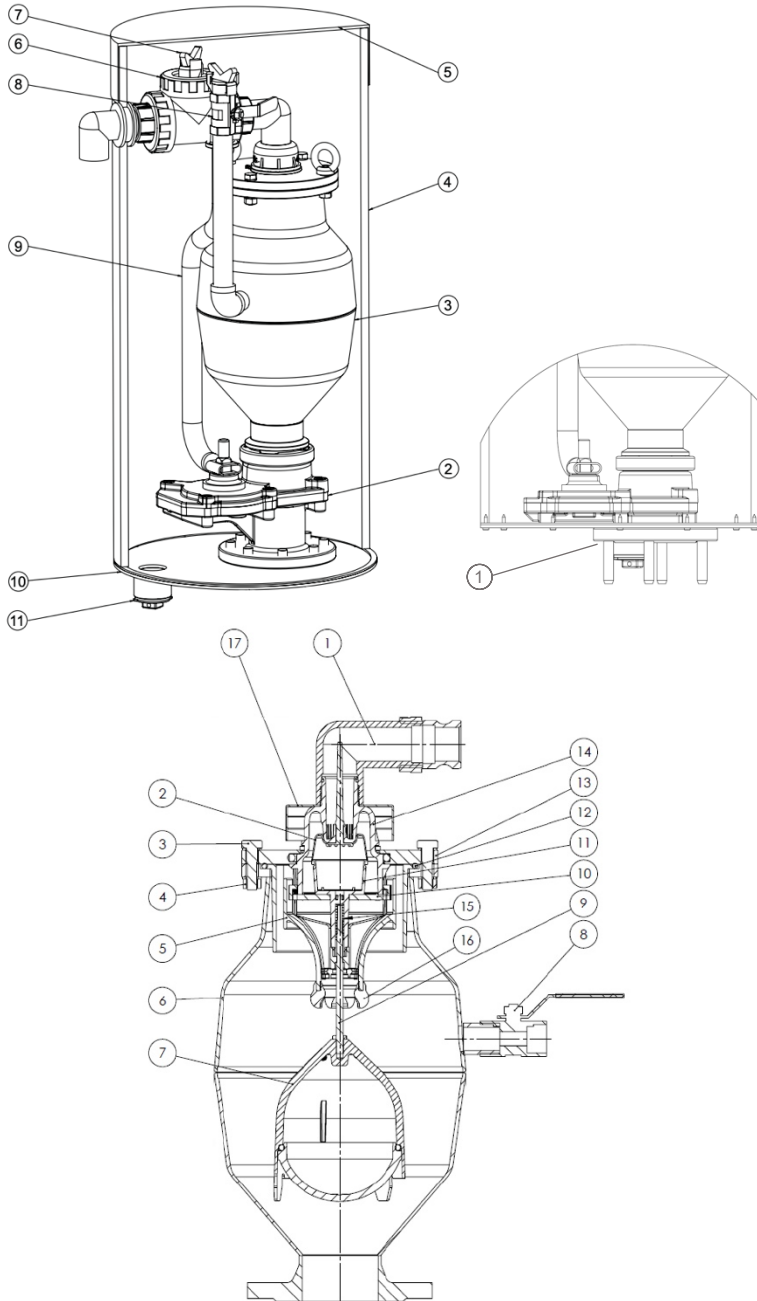

No.	Description	Material
1	Flange with bolts	Ductile Iron, epoxy powder coating
2	Shut-off device	Ductile Iron, epoxy powder coating
3	Air valve	316 Stainless Steel or Carbon Steel epoxy powder coating
4	Encapsulation	HDPE
5	Cover	HDPE
6	Three-way ball valve	PVC
7	Hose coupling	PA
8	Ball valve	316 Stainless Steel
9	Operating key	316 Stainless Steel
10	Base plate	Ductile Iron, epoxy powder coated
11	ZAK-Plug	Ductile Iron, epoxy powder coated

No.	Description	Material	Part Number
1	Outlet elbow	Polyethylene	9864000165
2	Diaphragm	HNBR	98640110
3	Hexagon bolt	316 Stainless Steel	9850000070
4	Hexagon nut	316 Stainless Steel	9864001050
5	Debris shield	PP Homopolymer	986400031
6	Body	316 Stainless Steel or carbon steel	9865010100
7	Float	Delrin® POM	98640046
8	Ball valve	316 Stainless Steel	9864001075
9	Float spindle	316 Stainless Steel	98641015
10	Debris screen	Delrin® POM	98640056
11	Diaphragm cup	Delrin® POM	98640066
12	O-ring 157x6	NBR	9864000135
13	Clamp flange	316 Stainless Steel or carbon steel	9865010015
14	Upper air valve	Delrin® POM	98640021
15	Valve spring	316 Stainless Steel	9864001030
16	Damper ring	NBR	98640031
17	UV shield	Polyethylene	9861000050

# Automatic Air and Vacuum Valve for Waste Water



## Model 986-01

Automatic air release and vacuum valve, stainless steel 316Ti,  
for operating range: 0 – 250 PSI (17.2 Bar),  
outdoor application possible



Type	Size ANSI	Maximum Pressure PSI/Bar	Body Material	Overall Width <b>B</b> Inch/mm	Overall Height <b>H</b> Inch/mm	Weight lbs./Kg
Thread	2" FNPT	250 PSI 17.2 Bar	Stainless Steel	10.75" 273 mm	24.4" 620 mm	35 lbs. 16Kg
Thread	3" FNPT	250 PSI 17.2 Bar	Stainless Steel	10.75" 273 mm	24.4" 620 mm	36 lbs. 16 Kg
Flange	2" ANSI	250 PSI 17.2 Bar	Stainless Steel	10.75" 273 mm	24.7" 627 mm	41 lbs. 19 Kg
Flange	3" ANSI	250 PSI 17.2 Bar	Stainless Steel	10.75" 273 mm	24.7" 627 mm	46 lbs. 21 Kg
Flange	4" ANSI	250 PSI 17.2 Bar	Stainless Steel	10.75" 273 mm	24.7" 627 mm	55 lbs. 25 Kg
Flange	6" ANSI	250 PSI 17.2 Bar	Stainless Steel	10.75" 273 mm	24.7" 627 mm	64 lbs. 29 Kg
Flange	8" ANSI	250 PSI 17.2 Bar	Stainless Steel	10.75" 273 mm	24.7" 627 mm	70 lbs. 32 Kg

### Features:

Automatic and infinitely variable air valve for waste water applications. Recommended for outdoor application in frost-free areas.

Maximum Operating Pressure: 250 PSI (17.2 Bar). Operating Range: 0 – 250 PSI (0 - 17.2 Bar).

Valve body of stainless steel 316 Ti. Valve seat does not contact the medium (air cushion). Two connections for effective flushing during maintenance work (top inlet flushing connection). All mechanical parts are manufactured of corrosion-resistant materials.

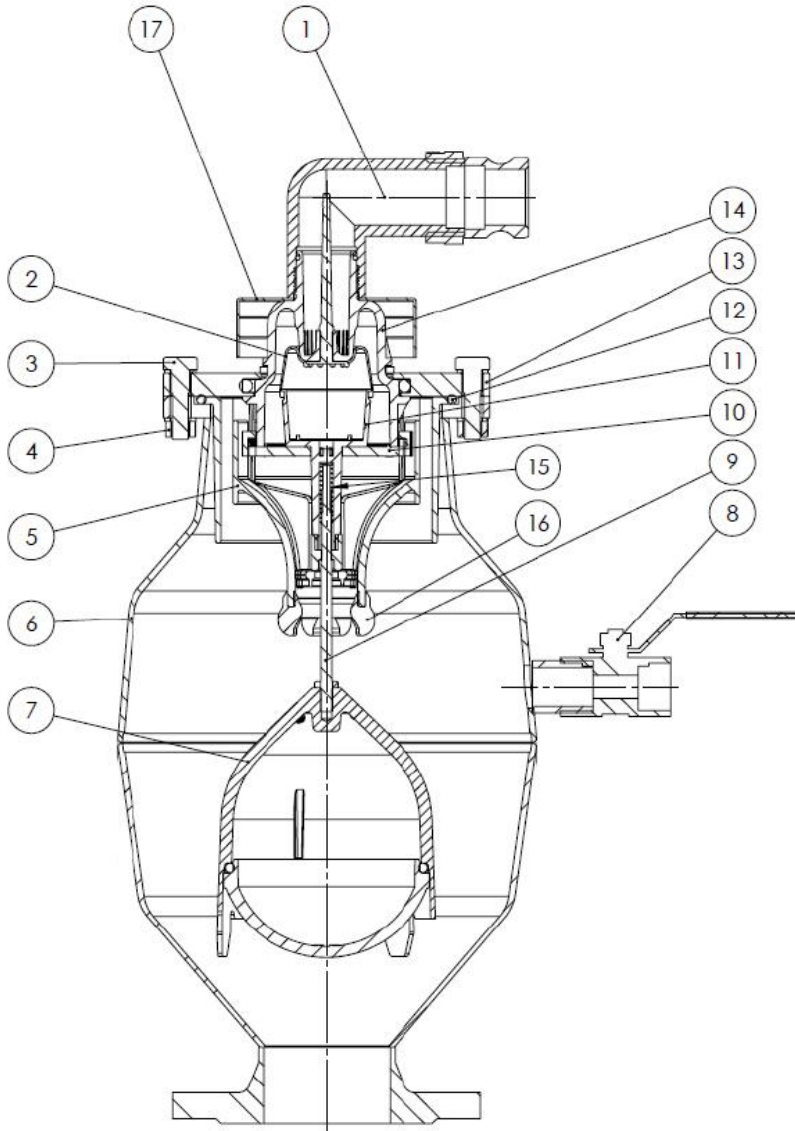

No.	Description	Material	Part Number
1	Outlet elbow	Polyethylene	9864000165
2	Diaphragm	HNBR	98640110
3	Hexagon bolt	316 Stainless Steel	9850000070
4	Hexagon nut	316 Stainless Steel	9864001050
5	Debris shield	PP Homopolymer	986400031
6	Body	316 Stainless Steel	9865010100
7	Float	Delrin® POM	98640046
8	Ball valve	316 Stainless Steel	9864001075
9	Float spindle	316 Stainless Steel	98641015
10	Debris screen	Delrin® POM	98640056
11	Diaphragm cup	Delrin® POM	98640066
12	O-ring 157x6	NBR	9864000135
13	Clamp flange	316 Stainless Steel	9865010015
14	Upper air valve	Delrin® POM	98640021
15	Valve spring	316 Stainless Steel	9864001030
16	Damper ring	NBR	98640031
17	UV shield	Polyethylene	9861000050

# Accessory for Automatic Air and Vacuum Valve 985-01



Lifting device for ARV Model 986-04 for ARV Sets and Manhole Free Sets

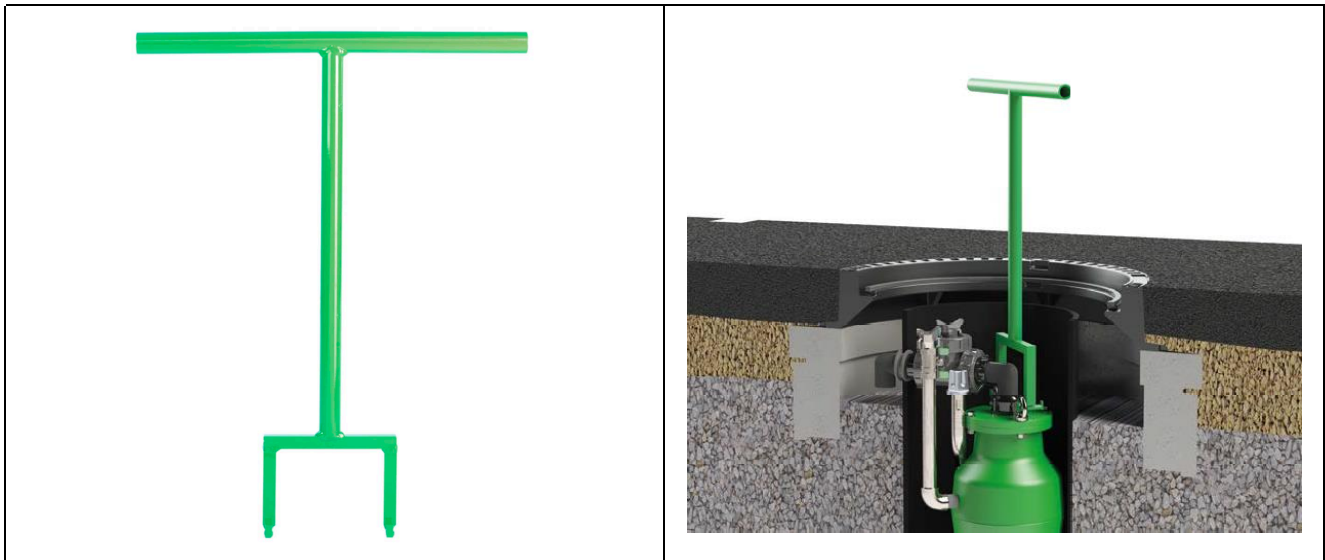

Article#	Material	Length ft/mm	Width ft/mm	Weight lbs./Kg
9850001000	steel, epoxy powder coated	2.6 ft 790 mm	2 ft 600 mm	11.2 lbs. 5.1 Kg

## Features:

For easy lifting and placing of H-TEC Automatic Air and Vacuum Release Valve Sets and ARV with shut-off for manhole installations of the H-TEC Model #986.

No bending into the manhole shaft.

Ergonomic correct lifting of a certain weight from below ground.

For an easy and quick ARV maintenance.

Another H-TEC product to support safety regulations, acc. to OSHA law.

**Note: ARV lifting is possible after isolation and pressure relieve of the air valve!**

# Accessory for Automatic Air and Vacuum Valve



## Model 985-00

Flushing device for H-TEC Model 986-04  
ARV Sets and Manhole Free Sets

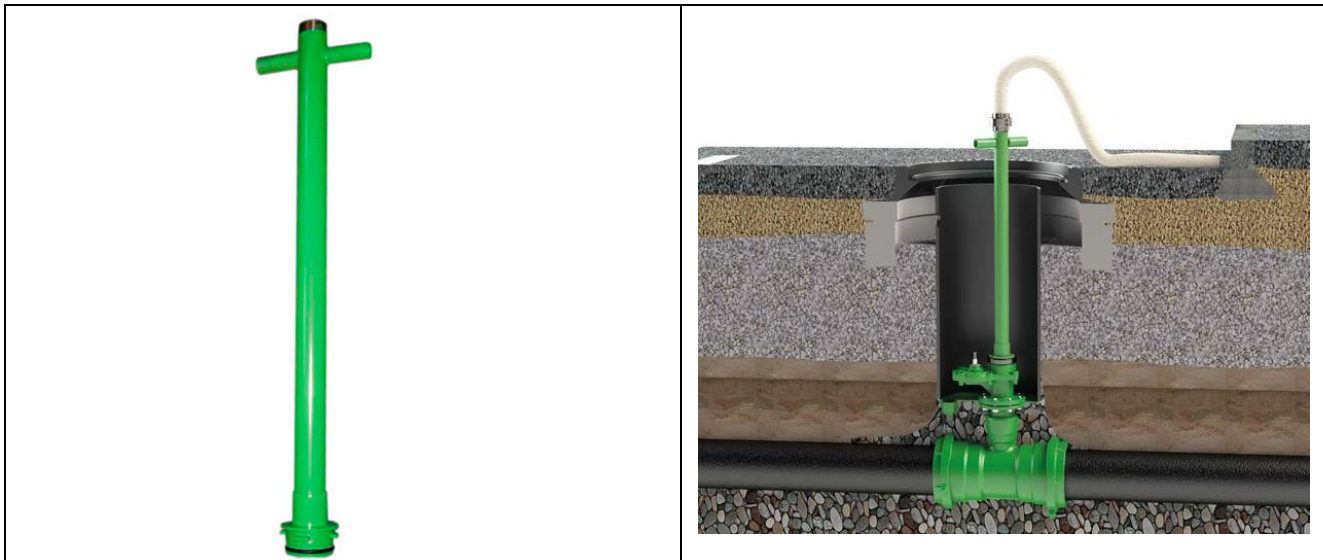

Article#	Material	Upper Connection	High ft/mm	Weight lbs./Kg
9850001200	steel, epoxy powder coated	2" male thread	3.4 ft 1,030 mm	17.2 lbs. 7.8 Kg

### Features:

For easy pipe flushing of a pipeline section after removing the ARV from H-TEC Automatic Air and Vacuum Release Valve Sets or ARV with shut-off for manhole installations of the H-TEC Model #986.

No bending into the manhole shaft.

Dual use increases efficiency:

- ARV location that eliminates confined space entry
- Entry point for flushing and cleaning

**Note:** For installation isolate the Air Valve, relieve pressure and remove the Air Valve. With the isolation valve closed, insert the Flushing Device lock into position. The isolation valve must be opened for free access to the pipeline.



# General Information

## 3.3 Air Release Valve Sets Accessories

The accessories for the air valve sets for sewage water Model: 986-04 facilitates the maintenance of air valves. The maintenance intervals for air release valves depend on the composition of the sewage water and the local conditions.

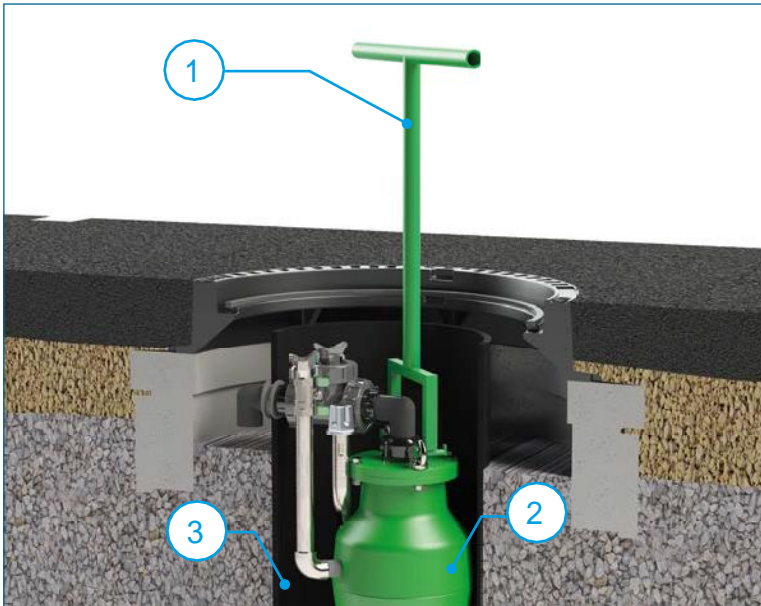

Valve lifting device (Model: 985-01)

The air valve lifting device Model: 985-01 (No. 1) serves as an aid for taking the air release valve Model: 986-00 (No. 2) out of the shaft of the air valve set Model: 986-04 (No. 3).

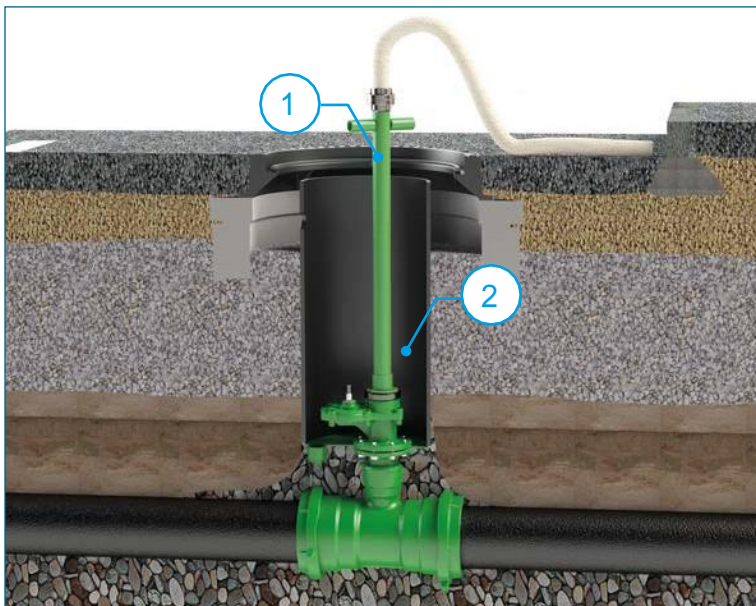

Flushing and water tapping set (Model: 985-00)

The flushing and water tapping set Model: 985-00 (No. 1) for the air valve set (Model: 986-04) allows an easy flushing of the sewage pipeline after taking the valve out of the PE shaft (No. 2).

Upper outlet: male thread 2"  
Lower connection: bayonet spigot end for establishing a form-locked connection with the bayonet socket

# General Information

## 3.2 Air Release Valve Sets

### Air Release Valve Sets

Air release valves are mainly installed in manholes. These are not only expensive to make but also expensive to maintain. Moreover, manholes require additional safety measures for entering, which are not necessary with air valve sets, as the latter can be serviced and maintained from ground level. The valve, the manhole, and the integral isolation valve are one unit.

#### Installation

For optimum operation, the air release valve sets have to be installed vertically on the line.

#### Pressure testing

Before pressure-testing a pipeline, the air release valves of the air release valve assemblies should be put out of operation.

#### Maintenance

Air valves have to be inspected at regular intervals and maintained as necessary.

Please note: Air valves contain compressed air. Prior to any maintenance work, air valves shall be put out of operation and depressurized. For maintenance information please refer to the respective operating and maintenance instructions.

### Installation situation – buried installation (sewage):

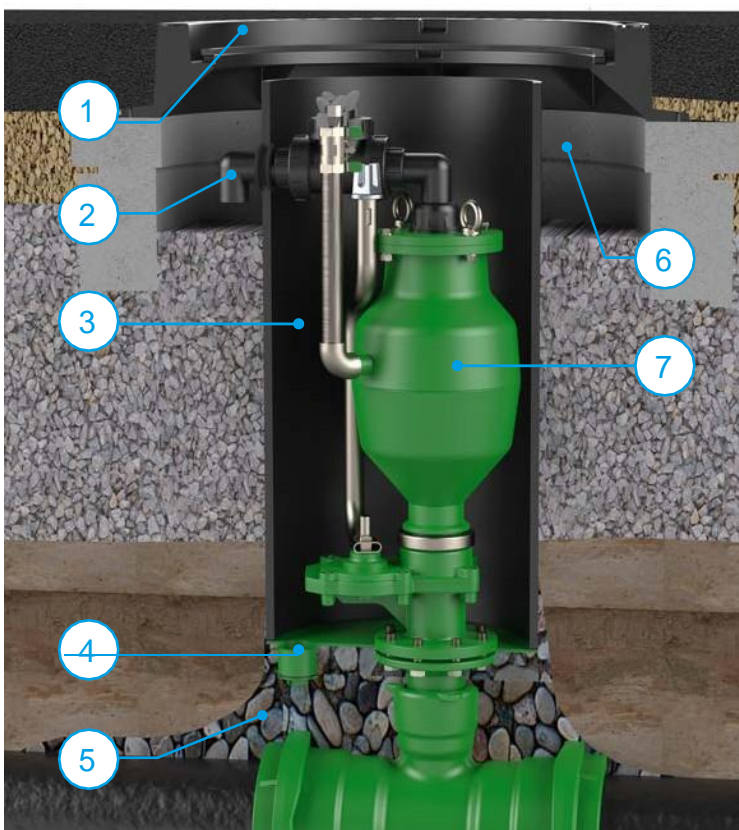

#### Legend

1. Surface box
2. Outlet elbow
3. PE shaft
4. ZAK® plug
5. Gravel layer suitable for drainage
6. Support ring for surface box
7. Air Release Valve 986-00