



Smith-Blair
a xylem brand

SPECIFICATION

HIGH PRESSURE FULL CIRCLE® REPAIR CLAMP

MODEL 267

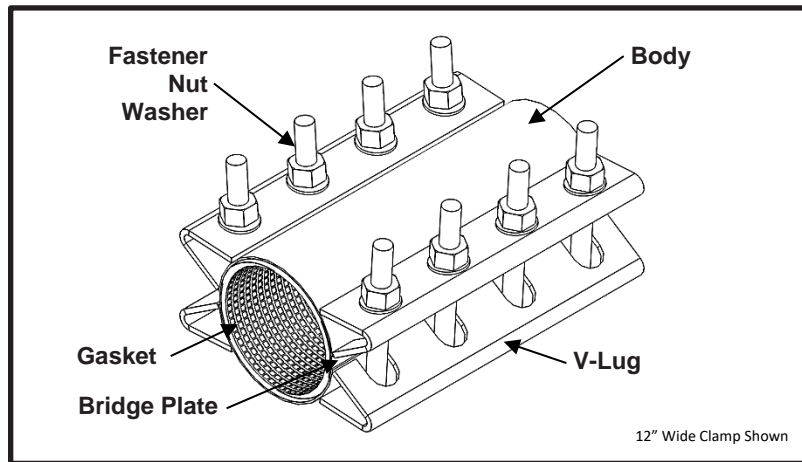

APPLICATIONS

Typical Uses

- Repair leaks due punctures, splits or holes (*not for full break*)
- Examples:

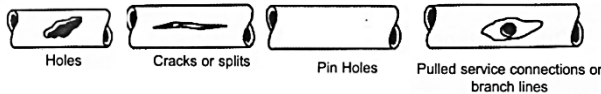

Standard Pipe Sizes

- 4" to 26" nominal

Standard Widths

- 12.00", 16.0", 20.0"

Type of Pipe

- Carbon Steel, Stainless Steel, Ductile Iron, PVC, HDPE DR17 or thicker (with spring washers), Asbestos Cement, Copper, Aluminum

Working Pressure

- 4.50" – 14.25" = 300 psi
- 15.30" – 25.80" = 200 psi

MATERIALS

Body

- Material: Carbon Steel per ASTM A283 Grade C or ASTM 569
OR
Stainless Steel T304L per ASTM A240

V-Lug

- Material: Carbon Steel per ASTM A283 Grade C
OR
Stainless Steel T304L per ASTM A240

Gasket

- Nitrile (Buna-N) per ASTM D2000
- Thickness: 0.25"
- Compounded to resist water, oil, natural gas, acids, alkalis, most (aliphatic) hydrocarbon fluids, and many other chemicals
- Temperature range: -20°F to +180°F

Bridge Plate

- Type 304 Stainless Steel quarter-hard per ASTM A240



Smith-Blair
a xylem brand

SPECIFICATION

HIGH PRESSURE FULL CIRCLE® REPAIR CLAMP

MODEL 267

Fasteners

- Material: High Strength Low Alloy (HSLA) Steel per AWWA C111/A21.11
OR
T304 Stainless Steel
- Size: 8.00" diameter and smaller = Bolt 5/8" – 11 UNC x 6" long, Track Head Oval Neck
8.01" – 20.13" diameter range = Bolt 3/4" – 10 UNC x 9" long, Track Head Oval Neck
20.14" diameter and larger = Stud 1.00" – 8 UNC x 15" long,

Nuts

- Material: HSLA Steel per AWWA C111/A21.11
OR
T304 Stainless Steel with fluoropolymer coating
- Size: 8.00" diameter and smaller = 5/8" – 11 UNC, Heavy Hex, Semi-Finished
8.01" – 20.13" diameter range = 3/4" – 10 UNC, Heavy Hex, Semi-Finished
20.14" diameter and larger = 1.00" – 8 UNC, Heavy Hex, Semi-Finished

Washer

- Material: Carbon Steel per ASTM A108
OR
T304 Stainless Steel
- Size: 8.00" diameter and smaller = 5/8" SAE
8.01" – 20.13" diameter range = 3/4" SAE
20.14" diameter and larger = 1.00" SAE

LISTINGS

- Certified to NSF/ANSI 61 and NSF/ANSI 372 (water service only)
- Meets applicable AWWA C230 standards (water service only)

OPTIONS

- Type 316 Stainless Steel body
- Type 304 or 316 Stainless Steel hardware with fluoropolymer coated nuts
- Alternative gasket material (e.g. Viton, EPDM, etc.)
- Spring washers for use of clamp on HDPE pipe
- Offset gaskets to allow for repairing longer cracks using multiple clamps
- Conductivity conductor feature

NOTES

- **Do not** use for repair of full breaks or joining pipe
- Spring washers **are required** when this product is used on DR17 or thicker HDPE pipe
- Xylem, Smith-Blair, SB stylized, Flexi-Coat, and Full Circle are registered trademarks of Xylem, Inc., or one of its subsidiaries
- These product specifications were correct at the time of publication and are subject to change without notice
- See the Smith-Blair website for part numbers and ordering information
- See the Smith-Blair website for warranty information
- See the Smith-Blair website for corrosion notice



THIS PRODUCT DOES NOT RESTRAIN PIPE MOVEMENT. Proper anchoring is required to prevent pipe pullout. Failure to anchor or improper anchoring can result in dangerous pipe content escape, property damage, serious injury, or death. Read the product installation instructions prior to installing this product.

30 Globe Ave, Texarkana, AR 71854
Ph: 870-773-5127 • Fax: 870-773-5212
Toll-Free Numbers: Ph: 800-643-9705 • Fax: 800-648-6792

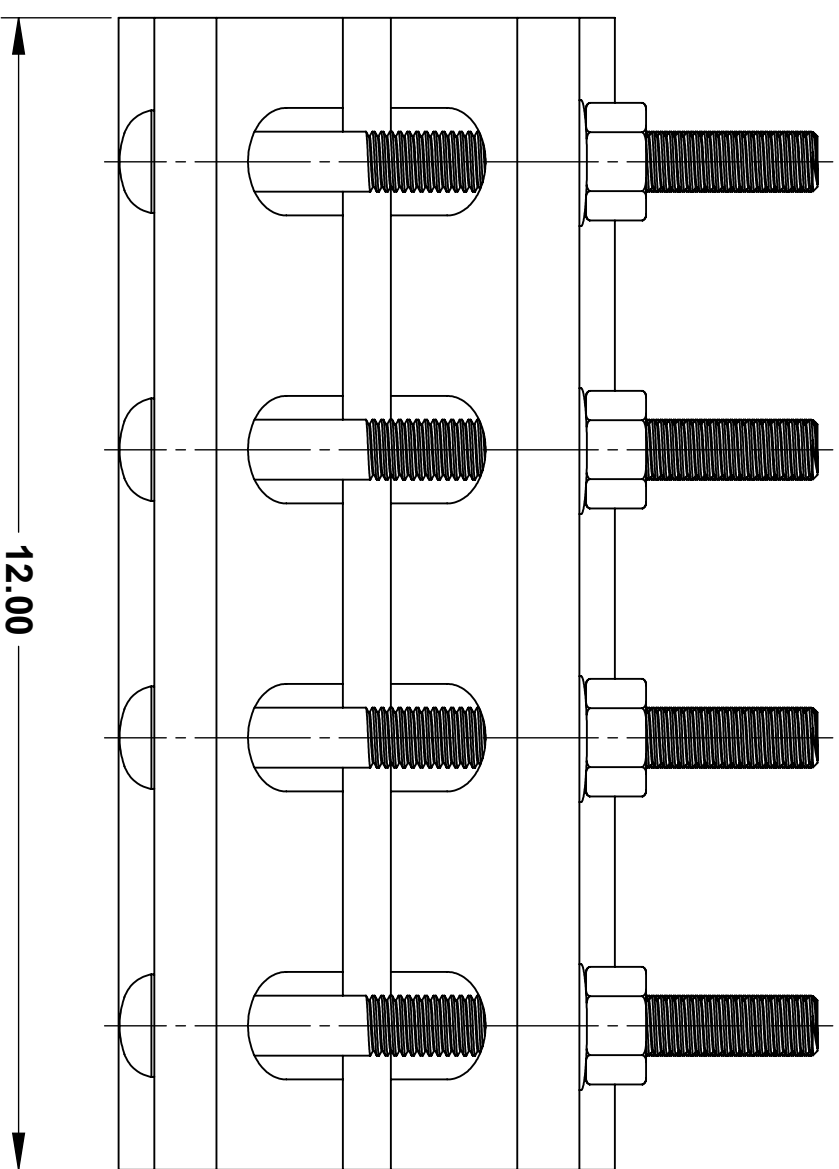
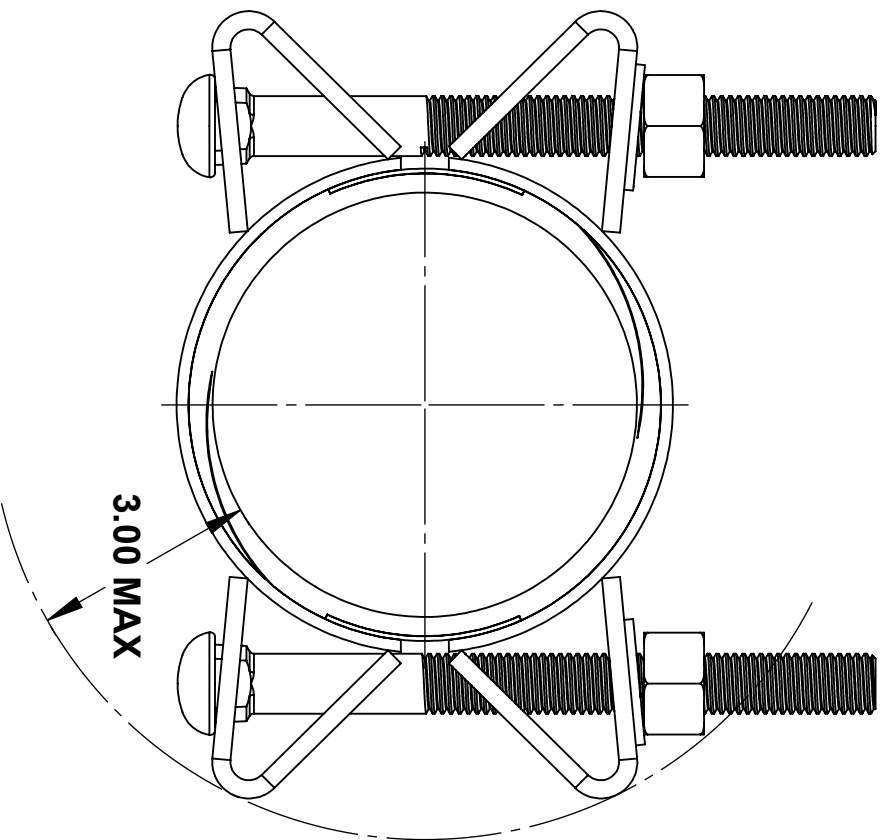

- NOTES:**
- SEE SMITH-BLAIR CATALOG FOR AVAILABLE PIPE DIAMETER AND WIDTH COMBINATIONS AS SOME COMBINATIONS ARE NOT AVAILABLE
 - 12.00" WIDE CLAMP SHOWN OTHER SIZES SIMILAR.

PIPE O.D. RANGE	HARDWARE		SOCKET SIZE
	QUANTITY	FASTENER SIZE	
4.46 - 8.00	8	5/8" x 6.00"	1-1/16"
8.01 - 10.00	6	3/4" x 9.00"	1-1/4"
10.01 - 20.13	8	3/4" x 9.00"	1-1/4"
20.14 - 26.60	6	1" x 15.00"	1-5/8"

TOLERANCES U.N.O.		NOTES:		APP'D	DATE
XX= ±.03	XXX= ±.015	REMOVE BURRS	AND SHARP EDGES	CK'D	DATE
FRACTIONS=	ANGLES=±1°	DO NOT SCALE DWG.			
MACH. FIN=	ALL DIMENSIONS	SCALE:	N/A	DRN	CHD
ARE IN INCHES.					DATE
					6/5/15

TITLE
SPECIFICATION
HIGH PRESSURE FULL CIRCLE® REPAIR CLAMP
MODEL 267

SMITH-BLAIR TEXARKANA, ARKANSAS		P/N	N/A
SPEC_267.DRW DWG. NO.		1 OF 1	10/27/2024
		SHEET	REV.